

Dallas Industries, Inc.

Straightener Break Roll Settings

7 Roll Straightener

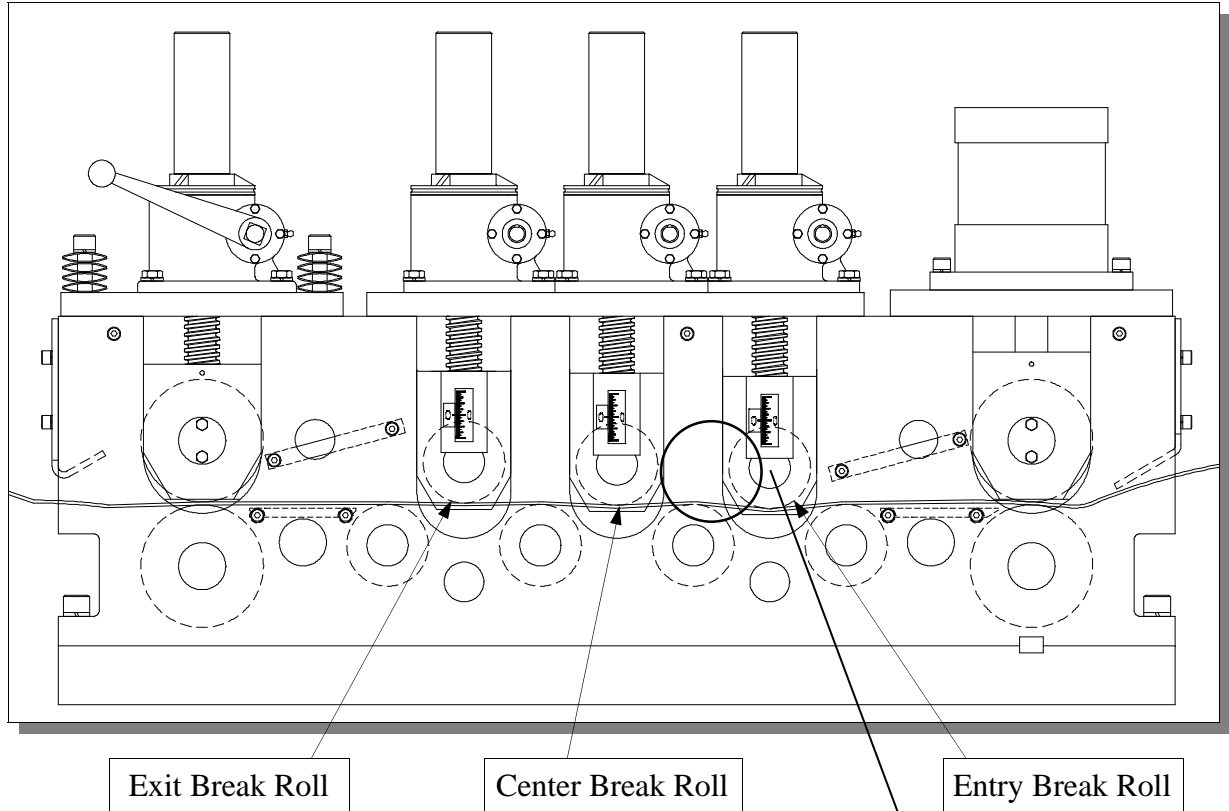

Stock Thickness	Gage	Exit Roll	Center Roll	Entry Roll
.250	2	1/4" +	15/64" +	7/32" +
.225	4	7/32" +	13/64" +	3/16" +
.200	5	3/16" +	11/64" +	5/32" +
.175	7	5/32" +	1/8" +	3/32" +
.150	9	1/8" +	3/32" +	1/16" +
.125	10	3/32" +	1/16" +	1/32" +
.100	12	1/16" +	1/32" +	0
.075	14	3/64" +	1/64" -	1/32" -
.060	16	1/32" +	3/64" -	1/16" -
.045	18	1/64" +	1/32" -	3/32" -
.030	21	0	1/16" -	1/8" -

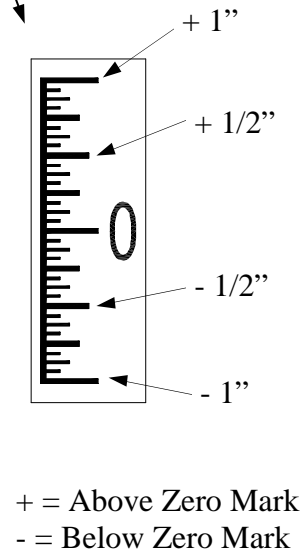

The above information is recommended starting values. Once equipment is running, adjustments will be necessary to produce desired straightness in material and or to compensate for certain material conditions. This information is provided as a guideline to setting Dallas press feeding equipment and should not overrule any recommended settings that were provided by the press manufacturer.